



TRANE

RTUA 108 - 217 RTCA 108 - 216

*Designed to perform
Built to last*



TRANE: Number 1 in rotary compressors applications

R TUA 108 - 217

Helical rotary liquid chillers

RTCA 108 - 216

Remote air cooled condensers

- *Nominal cooling capacity:
190 to 600 kW
(R22 - 50Hz)*
- *"Adaptive Control™"*



Since the introduction of RTWA, TRANE offers a complete range of liquid chillers fitted with rotary compressors covering the cooling capacity range from 50 up to 4000 kW.

For the largest cooling capacities, TRANE offers the centrifugal compressor liquid chillers. These machines have an excellent reputation for reliability. A survey published in the USA in 1988 revealed that more than 90% of the centrifugal chillers installed during the 50 last years were still in operation.

For lower cooling capacities, TRANE has introduced more recently, the 3-D® Scroll compressors and the Heliorotor Screw compressors.

Despite these technologies still being considered a novelty in some quarters, within TRANE this relates to

today's technology: for example the 3-D® Scroll compressors introduced in 1989 have completely replaced the reciprocating compressors for cooling capacities up to 160 kW. For the upper range, the water-cooled Screw compressor liquid chillers, series RTHA, introduced in 1988 is a very successful product: with more than 1500 machines installed every year worldwide, TRANE can be considered as the Number 1 in this area. TRANE has also introduced a range of air cooled Screw compressor liquid chillers.

Whatever the type of technology, the rotary compressors offer some very specific common benefits: superior energy efficiency and reliability combined with reduced sound and vibration level being the most obvious ones.

RTUA: A combination of the latest technological innovations in the field of liquid chillers



The RTUA offers in many areas a combination of the most advanced technologies available today:

- Screw compressor, with stepless capacity control and 5/7 lobes rotors profiles designed and patented by TRANE.
- Advanced microprocessor based «Adaptive Control™» including PID leaving chilled water temperature control and a serial communication link for easy integration into a Building Management System.

- Electronic expansion valve. Gives steadier operation, optimized evaporator efficiency and improved energy efficiency with reduced condensing pressure.
- High efficiency heat exchange surfaces : energy efficiency combined with reduced surface area.

RTUA: Designed to offer more attractive benefits in all areas



For the specifier:

- High energy efficiency, less floor space required: the unit can be more easily integrated into an existing plant room, which allows for an increase of the available cooling capacity.

- Higher application flexibility: ice storage, multiple operating conditions.
- Reduced sound and vibrations levels allowing installation in sensitive areas.

For the mechanical contractor:

- Compact design, reduced shipping weight: easier handling during site transportation.

For the operating contractor:

- State of the art motor protection: the unit control module permanently senses the current of each phase of the motor power supply as well as the temperature of the motor windings.
- «Adaptive Control™» anticipates any operating problems: the control module consequently takes corrective actions to enable the chiller to stay within operating limits to guarantee trouble free operation even under critical conditions. The chiller can continue to operate at a reduced load under these critical conditions until normal operation can be restored whereas a standard chiller would just stop as a fault.
- Sophisticated operator interface: the clear language display board allows for a quick and precise

identification of the operating status of the machine or of an operating fault.

- Serial link allows for a remote monitoring of the chiller.

For the owner:

- Superior energy efficiency reducing operating costs.
- Increase chiller life and drastically reduced maintenance costs: the compressors have been designed to operate for the whole life of the chiller without any major maintenance operations.
- Steady and safe operation: thanks to the stepless capacity control, the electronic expansion valve and the sophisticated control algorithms, the chiller can exactly match the required cooling capacity and maintain the chiller water outlet temperature within a range of +/- 0.3°C of the setpoint.
- Serial communication link facility to start and stop the chiller, modify the setpoints or to limit the current drawn from a remote location.

TRANE Helirotor Screw compressors: Superior energy efficiency and reliability

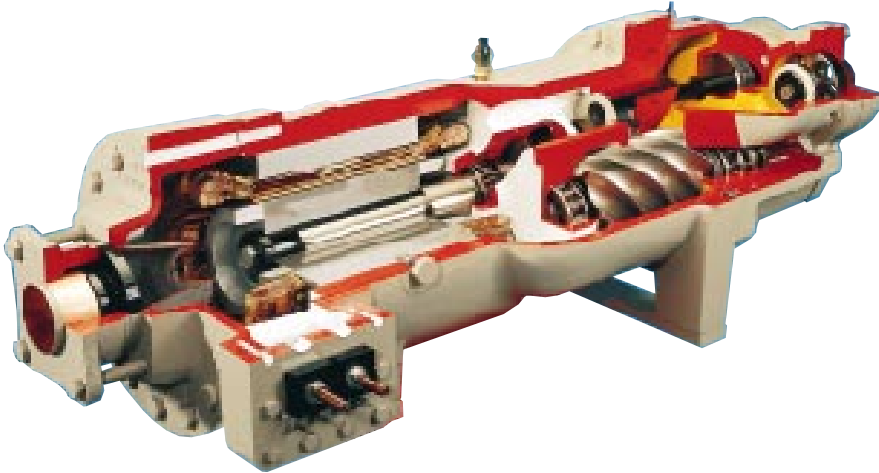

- **Less critical components** : only two rotating parts, reduced number of components and particularly of critical parts (the total number of critical components is on average 30 times lower compared to a standard reciprocating chiller).
- **Rugged design** : all potentially fragile components (suction and discharge valves, springs) have been eliminated. The compressors are fitted with class 5 bearings designed not to be replaced during compressor life time.

- **High precision machining** : the very precise rotor tip tolerance (10 micrometers) is achieved due to the most advanced machine tools available today. TRANE is able to build screw compressors with a reduced amount of leakage between the high and low pressure cavities. As a result, the energy efficiency of the compressor is considerably improved compared to the first generation of screw compressors which were in some cases derived from air compression technology.

- **Rotary compressor** : reduced sound and vibration level compared to reciprocating equipments. The overall sound level is lower and furthermore the shape of the sound spectrum is different: the sound level is inferior in the low frequencies bands.

- **Proven Design through Testing and Research** : at TRANE, we must fail compressors in the Laboratory to ensure they will not fail in the field. Without failures, there is no way to be certain whether the final design is satisfactory potentially unreliable. The compressor accelerated life test is a proven method to induce failure. This test is designed to over-stress a part and quickly identify any weak areas. The extreme test conditions far exceed actual field applications. TRANE engineers fail and redesign compressors until a reliable product is assured. Our leadership in helical rotary compressor technology is recognized worldwide. It is the basis for the successful introduction of the reliable TRANE Screw compressor, right from the start !

Better part load performance

The graph on the right compares the part load efficiency of the TRANE Helirotor compressor and of a reciprocating compressor. Due to superior part load performance the TRANE Helirotor uses less energy annually than a typical reciprocating compressor.

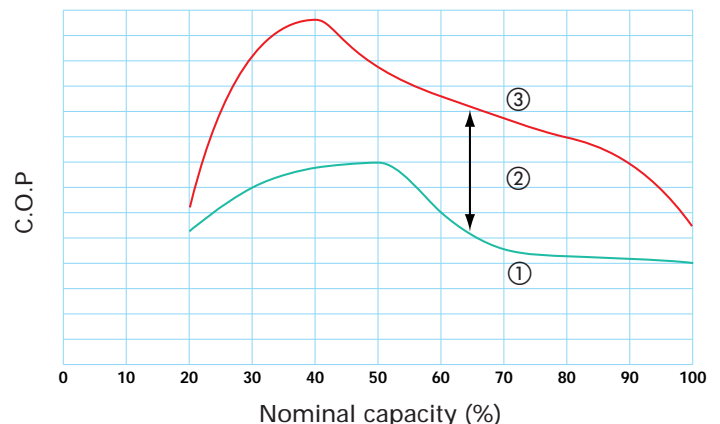

- ① Reciprocating compressor
- ② Efficiency gain
- ③ TRANE Helirotor compressor

Electronic expansion valve

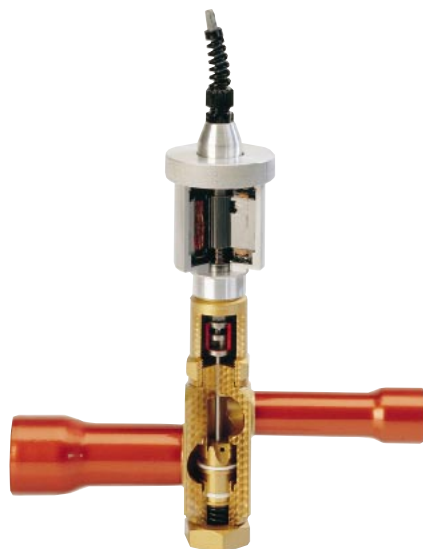

When coupled with Trane «Adaptive Control™» microprocessor, the electronic expansion valve significantly improves part load performance of the RTUA chiller by minimizing superheat in the evaporator and allowing the chiller to run at reduced condensing pressures.

Chillers which use conventional TXV must run at higher head pressures and consume more power at part load than necessary.

Additionally the electronic expansion valve and its control allow much better control over dynamic load and head changes. Under these conditions a conventional TXV may never achieve control stability and "hunting" and liquid slugging are common.

Precise refrigerant flow metering

The electronic expansion valve is actuated by a stepper motor. The exact valve position is permanently known by the Unit Control Module.

Quick response

To operate the valve from fully closed to fully open position requires less than 30 seconds. This is to compare with thermo-electric devices which have no stable position and require up to several minutes to fully close.

Superior tightness

Because of the superior tightness of the electronic expansion valve when full closed the liquid line solenoid valve is no more required.

It enables to further improve the reliability of the chiller by reducing the total number of moving parts.

«Adaptive Control™» Trouble-free installation, start-up and operation.



Trouble-free operation

The water cooled series RTWA utilizes the most advanced microprocessor control issued from the latest development in micro-electronics.

Control and protection of chiller were the two functions of previous chiller control design. «Adaptive Control™» keeps the chiller on line and makes the control "intelligent".

The «Adaptive Control™» means the system takes corrective action when any of the control variables approaches a limit condition at which the protection function of previous control schemes would normally shut down the chiller. Corrective action is achieved through combined actions of compressor unloader mechanism, electronic expansion valve modulation. Only when the control system has exhausted the corrective actions it can take and the unit is still violating an operating limit, the unit will be shut down.

The control logic of the P.I.D. type based on the leaving chilled water temperature integrates the control of variables (current drawn by the motor, evaporating and condensing temperature) maintains accurate control, minimizes the drift from the set-point and provides better building comfort.

Improved chiller and motor protection

The control system integrates all the functions necessary to ensure safe operation of the chiller in all applications and duty conditions :

- System safeties, such as oil, water, refrigerant pressure and temperature faults.
- Motor safeties. By monitoring the motor current on each of the 3 phases, the control system ensures protection against :
 - Overload at start-up and in operation.
 - Phase loss/Power loss.
 - Phase unbalance or reversal.
 - Over/Under voltage.
 - Welded contactors.

If a fault occurs, one of over 90 individual diagnostic and operating codes will displayed directly on the control module.

«Adaptive Control™», features summary

- Ensures safe operation of the chiller.
- Keeps chiller on line.
- Optimizes total chiller power consumption.
- Ensures total chiller reliability.
- Allows easy interface.
- Minimizes service expense.

Optional features

- Communication interface.
- External chilled water setpoint.
- External current limit setpoint.
- Ice making control.
- Chilled water temperature reset.

Operator interface

Easier than ever to use

The microprocessor is equipped with a two-line, forty character Clear Language Display. The display shows over 90 operating and status points. The control panel will display the most current diagnostic message and store the last 10 for more accurate diagnosis by Service personnel. Having the ability to diagnosis a problem via the control display will lower the service expense, as well as the downtime of the chiller.

Readability

Local operator interface with the system is accomplished using the 16 keys on the front of the Clear Language Display panel. The readout screen is a two line, 40 character liquid crystal with a backlight. The backlight allows the operator to read the display in low light conditions. The depression of any key will active the backlight.

Application flexibility

The UCM CLD is available with the output in six languages and either English or metric units.

Communication

The Unit Control Module (UCM) of the RTUA offers several communication levels which considerably simplify the implementation of a tele-monitoring of the chiller or its integration in a Building Management System (BMS).

Telemonitoring through a parallel link

Analog input and output ports allow chiller operation optimization or easy chiller monitoring when the machine is not integrated in a BMS.

Remote running and alarm contacts

The unit provides three single pole/double-throw contact closures to indicate whether :

- a failure has occurred,
- the compressor is running,
- the compressor is running at maximum capacity. This information may be used to authorize the start of an additional chiller.

External chilled water set-point and current limit set-point

The UCM allows the external setting independent of the front panel set-point by one of the following three means :

- a remote resistor (fixed or adjustable),
- a 2-10 VDC input,
- a 4-20 mA input.

In the same way, the motor current can be limited to optimize the total energy efficiency of the installation.

Integration in the Building Management System through the Serial link

The unit can be equipped upon request with a serial link communication card. All the data and functions available at the UCM front panel can be transmitted or accessed through the serial link.

Data which can be read

Following parameters can be read by the BMS through the serial link :

- Entering leaving evaporator water temperature.
- Motor current.
- Operating status : compressor stopped or running, compressor running at full load or auto-limitation.

More than 100 data can be accessed or transmitted.

Orders which can be sent to the chiller

The BMS can send following orders :

- Compressor start and stop.
- Motor current limit.
- Chilled water setpoint reset.

Superior «Adaptive Control™»

The diagram indicates the numerous variables that can be sensed by the Unit Control Module in order to ensure trouble free operation.

Refrigeration circuit

- ① Compressor
- ② Evaporator
- ③ Remote air cooled condenser (with integral subcooler)
- ④ Electronic expansion valve

Lubrication circuit

- ⑤ Oil separator
- ⑥ Oil cooler
- ⑦ Oil filter

Control circuit

- ① Compressor starter
- ② Phase loss/imbalance, under/over voltage protection
- ③ Electronic expansion valve self diagnostic and prepositioning, refrigerant flow metering
- ④ Refrigerant temperature entering the evaporator
- ⑤ Refrigerant temperature leaving the evaporator
- ⑥ Oil heating
- ⑦ Oil circuit solenoid valve
- ⑧ Oil pressure
- ⑨ Compressor capacity control
- ⑩ Motor winding temperature
- ⑪ Water temperature entering the evaporator
- ⑫ Water temperature leaving the evaporator
- ⑬ Chilled water circuit flow (site wired option)
- ⑭ Condenser refrigerant temperature
- ⑮ Air flow control
- ⑯ Ambient air temperature

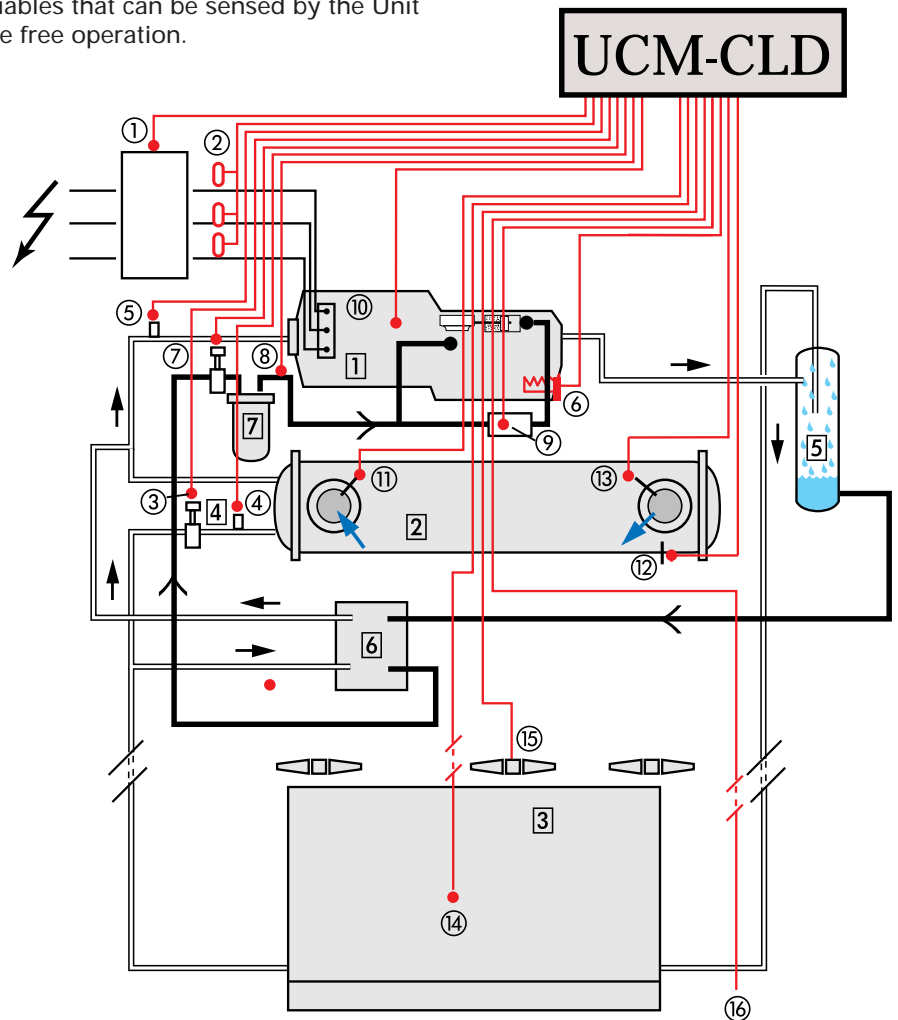

Remote control panel

TRANE RTUA chiller is available with twisted pair connection to a remote control panel. Chiller operation can be controlled similarly to the control interface on the chiller itself. All through a twisted pair of wire unit can be turned on or off, change the chilled water setpoint, and display over 90 diagnostics conditions.

Remote control panel can be mounted so access to chiller information is just step away and no need to go into the chilled water plant.



RTCA air cooled condensers are designed to be combined with TRANE RTUA liquid chillers but are also suitable for any other application requiring remote air cooled refrigerant condensers.

TRANE component integration means optimum selection, performance and compatibility, built to advanced engineering standards.

Features

- V-coil arrangement : low profile, compact design.
- Choice of 4 fan speeds : 9.2, 11.2, 12.3 and 15.2 rev/s to allow optimization of heat transfer and noise emission requirements.
- Two-speed fans (option).
- Integral subcooling circuits.

The RTCA condensers are suitable for installation in refrigeration systems with total heat rejection capacities from 70 to 800 kW. The choice between three motor speeds permits a unit to be selected for optimum performance in relation to the desired sound level. All RTCA condensers feature energy-saving integral subcooling circuits.

Subcooling of the liquid refrigerant increases the net refrigeration effect of the system without increasing the compressor power consumption.

Exceptionally compact design, maximum selection flexibility and simplified installation, the RTCA condenser series minimizes installation costs.

Subcooling

Subcooling of the condensed refrigerant below its saturation temperature increases the system refrigeration effect at constant compressor power input and thus improves the system coefficient of performance by 8 to 15 % at typical selection conditions.

When selecting the condenser, the system operating point without subcooling is to be determined first and then the capacity obtained multiplied with the applicable subcooling correction factor in order to determine the total available system refrigeration effect. The selection of the evaporator must take into account the enthalpy increase due to the subcooling of the liquid refrigerant.

Subcooling also eliminates or reduces partial evaporation of liquid refrigerant due to pressure drop or change in elevation ahead of the expansion valve. Gas in the liquid refrigerant may lead to insufficient feeding of the evaporator, operational problems and shortage of system capacity.

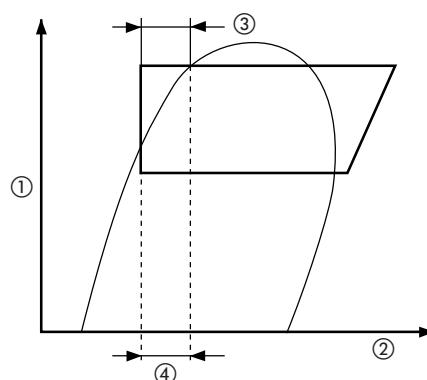

- ① Pressure
- ② Specific enthalpy
- ③ Subcooling
- ④ Increase in refrigeration effect

Air flow

The discharge air flow pattern of condensers selected with low fan speed tends to favor hot air recirculation. Hot air recirculation increases the energy consumption of the system and may lead to high pressure nuisance cut-outs when operating close to the design ambient temperature.

Very low fan speeds should thus be avoided whenever possible and the condenser installed in such a way that the air flow is not obstructed or restricted in any manner.

Undivided responsibility

TRANE was one of the first manufacturers to offer large capacity air cooled systems and has accumulated considerable design, manufacturing and field operating experience.

The choice of a complete TRANE system, including the compressor, evaporator and the condenser offers the designer, installer and owner the advantages of an optimized selection and undivided responsibility for the design, the quality and the operation of the complete system, backed by a leading supplier of the complete range of air conditioning systems and components.

RTUA/RTCA: Developed in order to provide superior acoustical performance

The installation of a split system offers a good economic alternative to satisfy the chilled water demand for cooling a building, particularly in the case of new construction. At the same time though, the installation of an outdoor machine - on the roof or in a courtyard - makes it necessary to take account of the impact it will have on the environment, especially the noise perceived by neighbours. More frequently than before, designers and architects are now having to address both local regulations and demands to improve the environmental conditions with respect to noise emanating from air conditioning equipment. To meet these stringent sound specifications, TRANE developed a new range of air cooled condensers for outdoor installation.

Low speed fans

For the RTCA Low Noise fans with aerofoil section blades running at 680 rpm have been selected to optimise the acoustical and mechanical performance and to provide high chiller efficiency without risk of the air being recirculated to the condenser coils.



Application examples

No elevation difference

Restrictions :

- Total distance between components should not exceed 60 m (actual) or 90 m (equivalent).
- Liquid line height must not exceed 5 m from the base of the air cooled condenser unit.
- Discharge line trap is recommended leaving the oil separator if the discharge piping runs for more than 3 m (actual) horizontally above the RTUA unit.

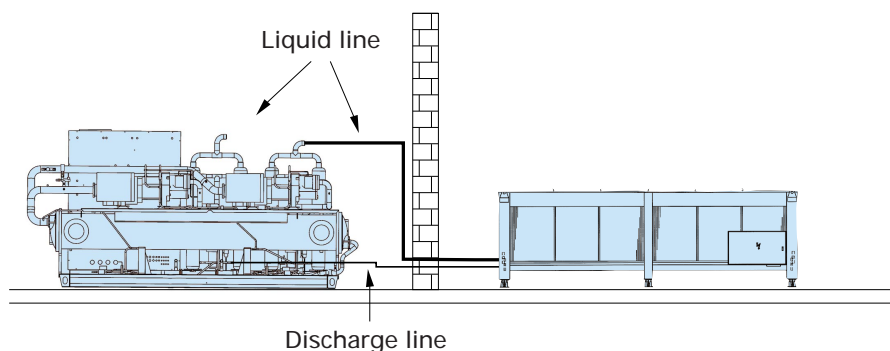

RTCA condenser above the RTUA compressor / chiller

Restrictions :

- Total distance between components should not exceed 60 m (actual) or 90 m (equivalent).
- Elevation difference greater than 30 m (actual) will result in at least a 2% efficiency decrease.

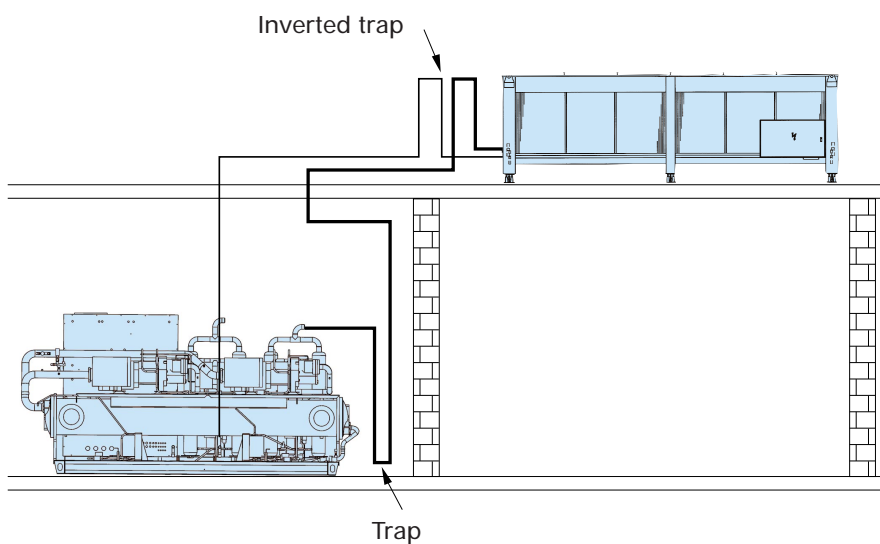

RTCA condenser below RTUA compressor / chiller

Restrictions :

- Total distance between components should not exceed 60 m (actual) or 90 m (equivalent).
- Liquid line risers must not exceed 5 m from the base of the air cooled condenser.

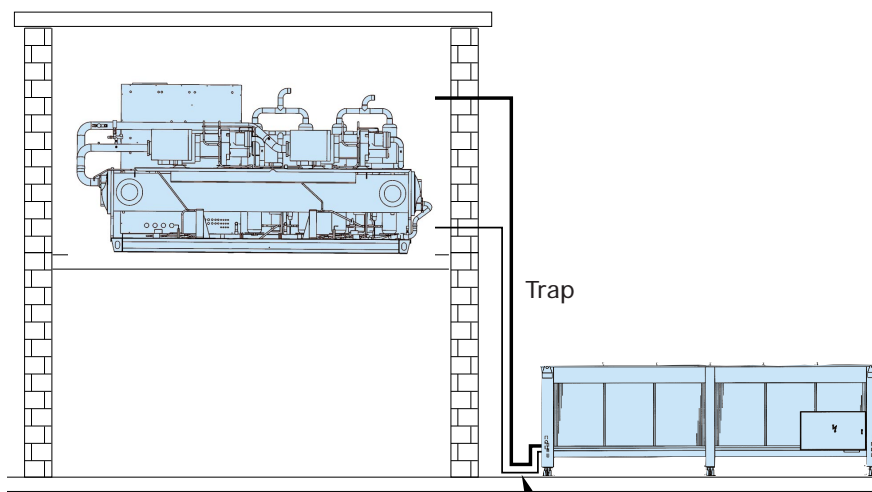

Performance data

Unit Size RTUA & RTCA	Leaving chilled water temperature (°C)	Condenser entering air temperature (°C)					
		25		30		35	
		Cooling Cap. (kW)	Power Input (kW)	Cooling Cap. (kW)	Power Input (kW)	Cooling Cap. (kW)	Power Input (kW)
RTUA 108	5	203	60	188	65	174	70
&	7	214	62	199	97	184	72
RTCA 109	9	225	64	210	69	194	73
RTUA 109	5	228	65	213	71	198	77
&	7	242	67	226	73	211	78
RTCA 111	9	256	69	240	75	222	80
RTUA 110	5	283	74	265	80	247	87
&	7	299	76	280	83	262	89
RTCA 113	9	315	79	296	85	276	92
RTUA 207	5	198	56	186	61	173	66
&	7	211	58	198	63	185	67
RTCA 209	9	224	60	210	64	197	69
RTUA 209	5	233	64	218	69	204	74
&	7	248	66	234	71	219	76
RTCA 211	9	264	68	249	73	233	78
RTUA 211	5	299	81	282	87	265	93
&	7	318	83	300	90	284	95
RTCA 213	9	337	86	319	92	301	98
RTUA 212	5	340	98	321	105	301	112
&	7	363	101	342	108	322	115
RTCA 213	9	384	105	363	111	341	118
RTUA 213	5	413	118	383	128	354	138
&	7	437	122	406	132	375	141
RTCA 215	9	460	126	427	136	395	145
RTUA 215	5	464	129	433	140	401	152
&	7	493	133	460	144	427	155
RTCA 216	9	521	137	486	148	452	159
RTUA 216	5	498	146	465	158	432	170
&	7	528	151	493	163	457	174
RTCA 216	9	557	156	519	167	482	179
RTUA 217	5	575	147	538	159	501	172
&	7	609	152	570	164	532	175
2 RTCA 113	9	642	157	602	169	560	182

(1) With D T evaporator: 6°C, fouling factor: 0.044 m² K/kW, standard heat exchangers, electrical power supply 50Hz, refrigerant R22.

General data

Unit size	RTUA	108	109	110
Nominal motor rating	(kW)	98	113	131
Compressor type	CHHN	70	85	100
Capacity modulation capability		- - - Continuous: 20-100 % - - -		
Starting amps (1)(2)	(A)	433	539	600
Maximum amps (1)(3)	(A)	154	177	207
Oil heater	(W)	150	150	150
Control circuit	(VA)	1600	1600	1600
Evaporator type		ES71	ES81	ES101
Evaporator-water content	(l)	145	134	118
Operating charges				
Refrigerant	(kg)	15	16	17
Oil	(l)	14	14	14
Operating weight (4)	(kg)	1630	1710	1710

Unit size	RTUA	207	209	211	212	213	215	216	217
Nominal motor rating	(kW)	49	56	65	76	98	113	113/131	131
Compressor type	CHHN	35	40	50	60	CHHB 70	85	85/100	100
Capacity modulation capability		- - - Continuous: 17-100 % - - -				- - - Continuous: 10-100 % - - -			
Starting amps (1)(2)	(A)	288	348	419	507	587	716	777	807
Maximum amps (1)(3)	(A)	158	180	212	256	308	354	384	414
Oil heater	(W)	150	150	150	150	150	150	150	150
Control circuit	(VA)	1600	1600	1600	1600	1600	1600	1600	1600
Evaporator type		ES70	ES80	ES100	ES120	ES140	ES170	ES170	ES200
Evaporator-water content	(l)	145	134	118	106	269	223	223	204
Operating charges									
Refrigerant	(kg)	2 x 10	2 x 11	2 x 12	2 x 13	2 x 18	2 x 20	2 x 20	2 x 22
Oil	(l)	2 x 8	2 x 8	2 x 8	2 x 8	2 x 14	2 x 14	2 x 14	2 x 14
Operating weight (4)	(kg)	1660	1670	1690	1710	2580	2785	2785	2815

(1) 400V/50Hz/3Ph power supply.

(2) With part winding start. One compressor at full load, the other one starting.

(3) To be taken into account for the sizing of power cables.

(4) With compressor sound enclosure, refrigerant and oil operating charge and heat exchanger water content.

Unit size	RTCA	108	109	111	113	115	116	208	209	211	213	215	216
Number of circuits		1	1	1	1	1	1	2	2	2	2	2	2
Number of fans		4	4	6	8	8	12	4	4	6	8	8	12
Fan Diameter	(mm)	762	762	762	762	762	762	762	762	762	762	762	762
Standard version :													
Fan speed	(rev./mn)	915	915	915	915	915	915	915	915	915	915	915	915
Fan motor size	(kW)	1.9	1.9	1.9	1.9	1.9	1.9	1.9	1.9	1.9	1.9	1.9	1.9
Fan FLA 400/50/3	(A)	4,2	4,2	4,2	4,2	4,2	4,2	4,2	4,2	4,2	4,2	4,2	4,2
Low noise version :													
Fan speed	(rev./mn)	680	680	680	680	680	680	680	680	680	680	680	680
Fan motor size	(kW)	0.8	0.8	0.8	0.8	0.8	0.8	0.8	0.8	0.8	0.8	0.8	0.8
Fan FLA 400/50/3	(A)	2,4	2,4	2,4	2,4	2,4	2,4	2,4	2,4	2,4	2,4	2,4	2,4
R22 operating charge	(kg)	22	26	36	44	52	72	2x11	2x13	2x18	2x22	2x26	2x36
Operating weight (2)	(kg)	810	890	1090	1535	1770	2050	810	890	1090	1535	1770	2050

(1) 400V/50Hz/3Ph power supply.

(2) Weight with aluminium fins.

RTUA 108 to 110 - Dimensions

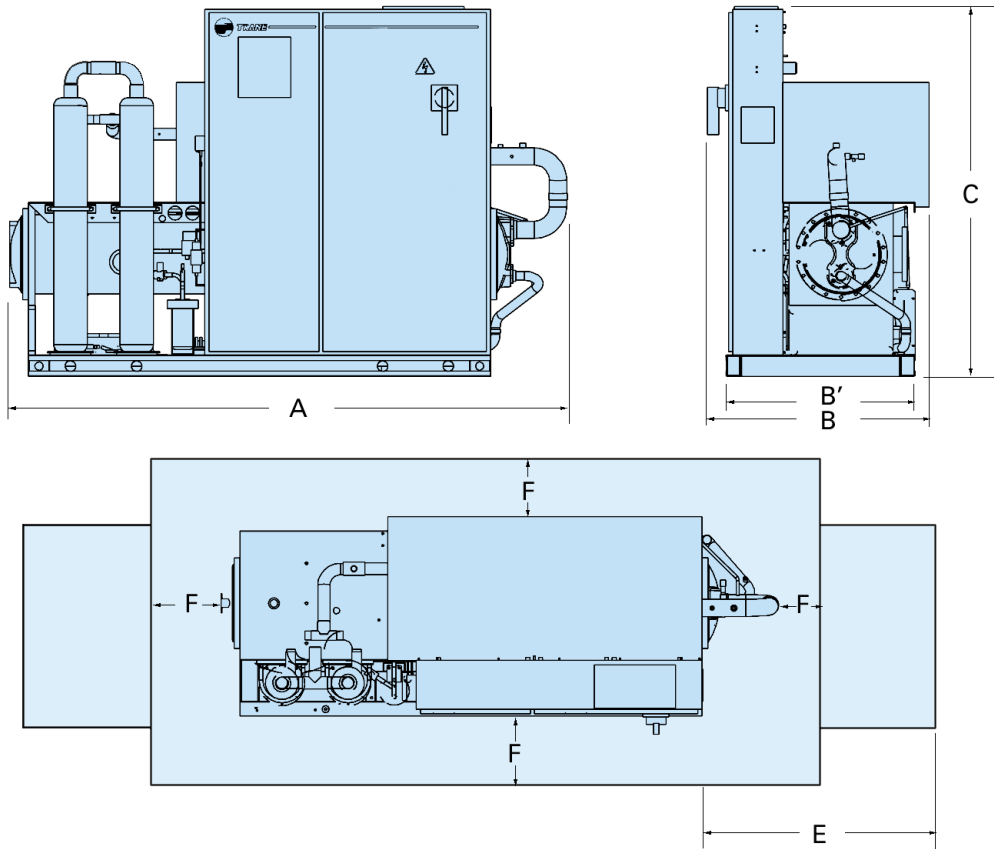

Recommended space envelope

Unit size	RTUA		108	109	110
Length	A	(mm)	2536	2536	2536
Width	B	(1) (mm)	860	860	860
	B'	(2) (mm)	1010	1010	1010
Height	C	(2) (mm)	1715	1715	1715
Clearance	E	(3) (mm)	2000	2000	2000
	F	(4) (mm)	800	800	800
Evaporator hydraulic connections			----- Flanges 5" / DN125 / PN16 -----		
Electrical connection	(mm)		370 x 200	370 x 200	370 x 200

- (1) With compressor sound enclosure and disconnect switch handle removed.
 (2) With compressor sound enclosure and disconnect switch handle mounted.
 (3) Clearance for retubing : can be on either end of the chiller
 (4) Clearance all around the unit in order to achieved usual maintenance operations.

RTUA 207 to 212 - Dimensions

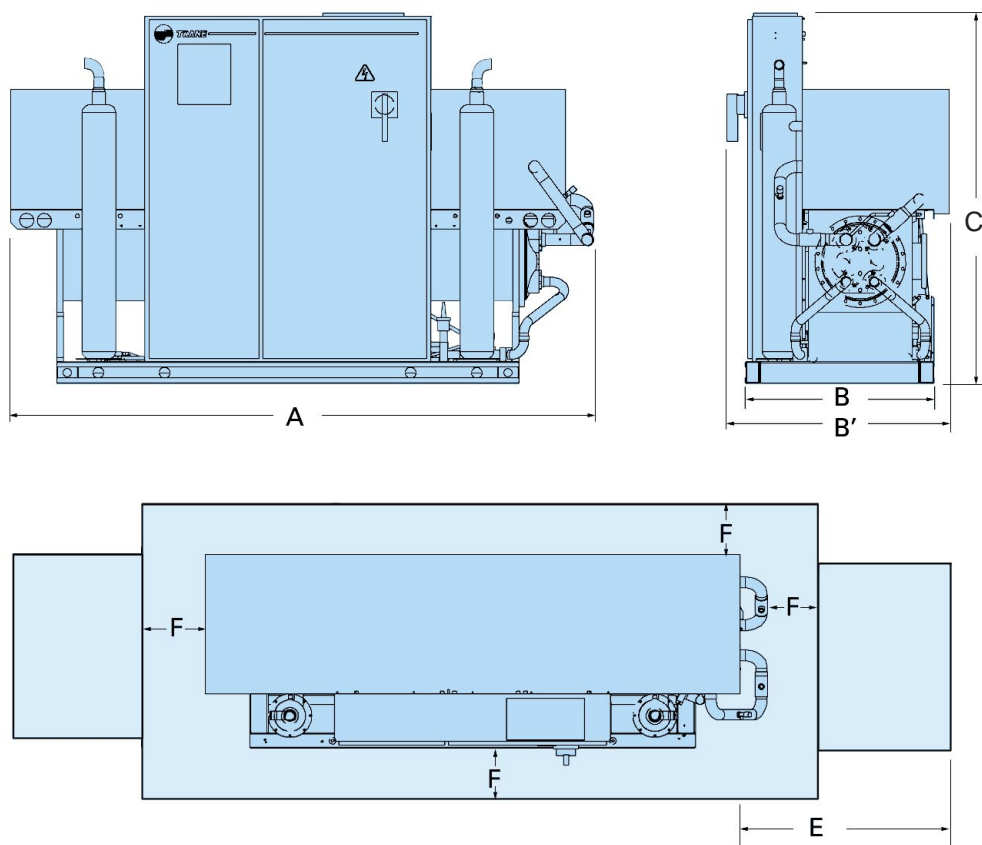

 Recommended space envelope

Unit size	RTUA		207	209	211	212
Length	A	(mm)	2653	2653	2653	2653
Width	B	(1) (mm)	860	860	860	860
	B'	(2) (mm)	1010	1010	1010	1010
Height	C	(2) (mm)	1715	1715	1715	1715
Clearance	E	(3) (mm)	2000	2000	2000	2000
	F	(4) (mm)	800	800	800	800
Evaporator Hydraulic connections			----- Flanges 5" / DN125 / PN16 -----			
Electrical connection		(mm)	370 x 200	370 x 200	370 x 200	370 x 200

(1) With compressor sound enclosure and disconnect switch handle removed.

(2) With compressor sound enclosure and disconnect switch handle mounted.

(3) Clearance for retubing ; can be on either end of the chiller

(4) Clearance all around the unit in order to achieved usual maintenance operations.

RTUA 213 to 217 - Dimensions

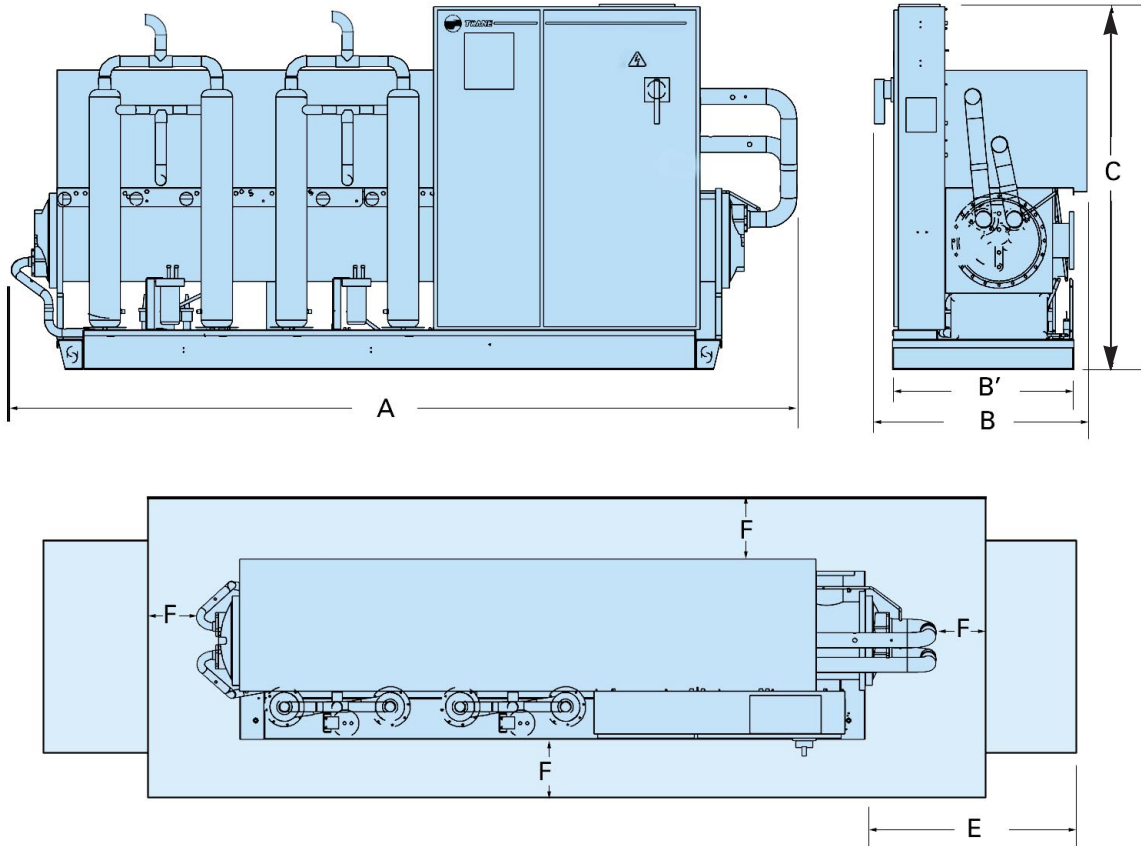

Recommended space envelope

Unit size	RTUA		213	215	216	217
Length	A	(mm)	3834	3834	3834	3834
Width	B	(1) (mm)	885	885	885	885
	B'	(2) (mm)	1040	1040	1040	1040
Height	C	(2) (mm)	1813	1813	1813	1813
Clearance	E	(3) (mm)	3000	3000	3000	3000
	F	(4) (mm)	800	800	800	800
Evaporator Hydraulic connections			----- Flanges 6" / DN150 / PN16 -----			
Electrical connection		(mm)	370 x 200	370 x 200	370 x 200	370 x 200

(1) With compressor sound enclosure and disconnect switch handle removed.

(2) With compressor sound enclosure and disconnect switch handle mounted.

(3) Clearance for retubing : can be on either end of the chiller

(4) Clearance all around the unit in order to achieved usual maintenance operations.

RTCA Dimensions

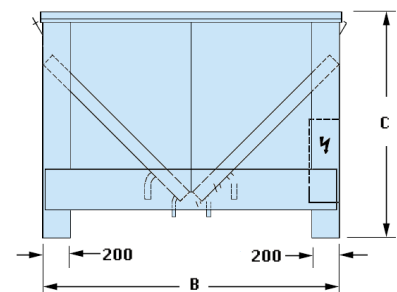
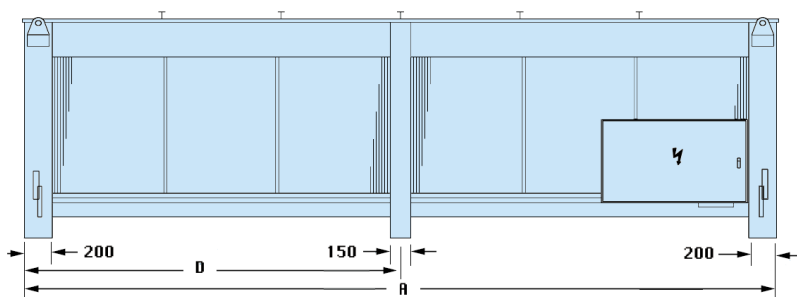
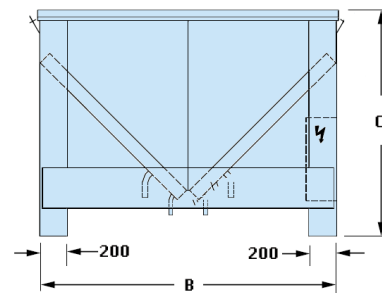
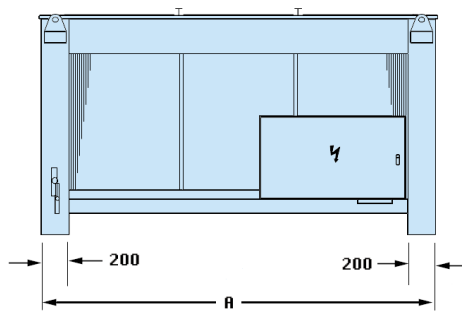

Model RTCA	Length A	Width B	Height C	D	Hot gas connection (1)	Liquid connection (1)
108-109-111 208-209-211	2840	2140	1550	-	Ø 1"5/8	Ø 1"1/8
113-213	4580	2140	1550	2290	Ø 1"5/8	Ø 1"1/8
115-116 215-216	5420	2140	1550	2710	Ø 1"5/8	Ø 1"1/8

(1) Sizes 108 to 211 : 2 each hot gas and liquid line connections (2 coils).

Sizes 113 to 216 : 4 each hot gas and liquid line connections (4 coils).

(2) Recommended clearance (coil sides) = 1200 mm. Between two condensers = 2400 mm, other sides 800 mm.
Contact Trane for more detailed application information.

Water side pressure drop

Evaporator

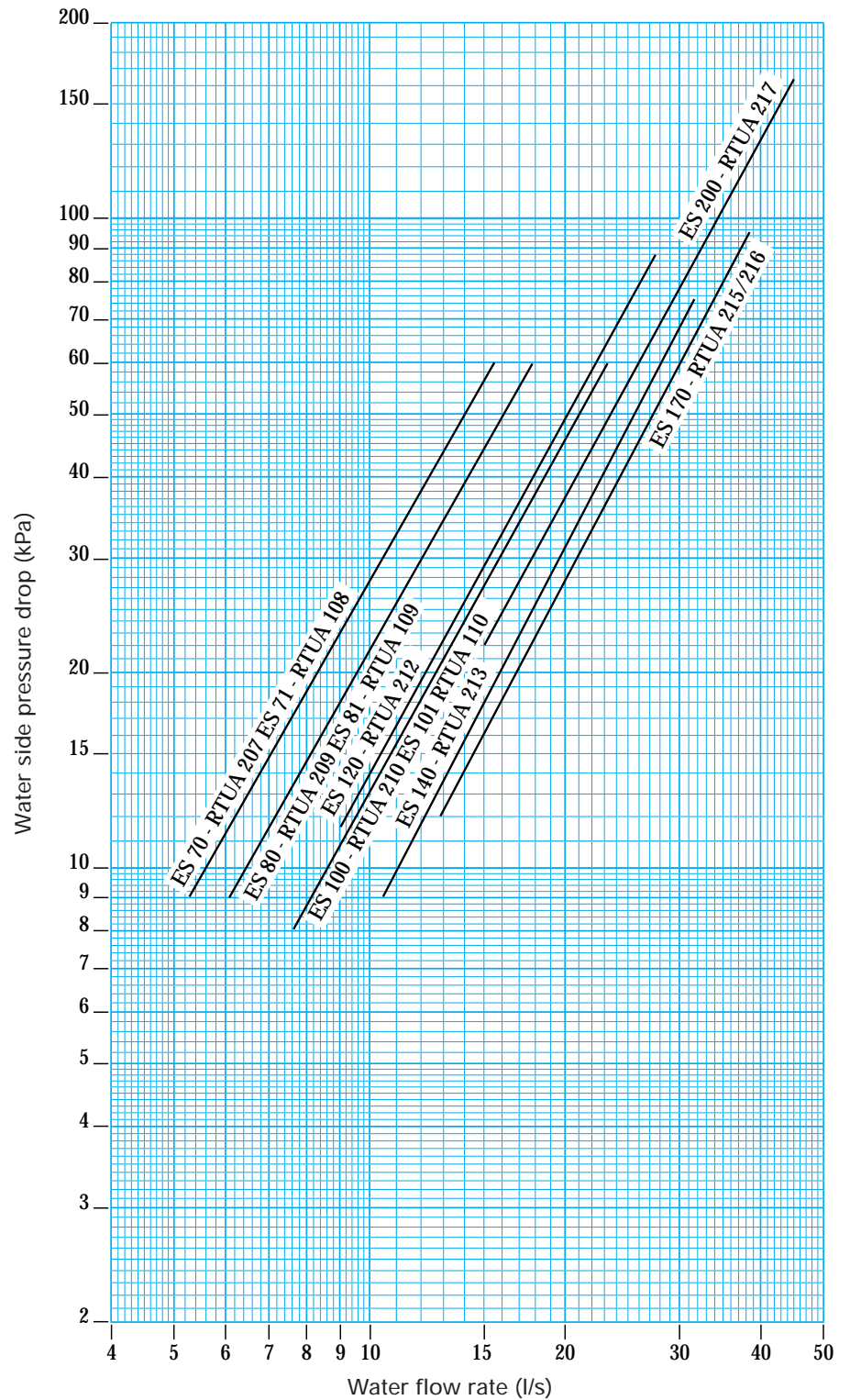

RTUA Mechanical specifications

Compressor liquid chiller, series RTUA fitted with semi-hermetic direct drive screw compressor, shell and tube evaporator, microprocessor based «Adaptive Control™» module, factory mounted starter panel.

General construction

Welded evaporator assembly fitted on a structural steel profiles frame.

Compressor supporting plate designed to allow installation of the compressor sound enclosure on site.

Double door electrical panel.

Compressors and lubrication oil system

One or two semi-hermetic, accessible direct drive, 2950 rpm dual screw compressor with:

- Capacity control slide valve.
- Pressure lubricated, class 5 rolling element bearing groups support the rotor assembly.
- Squirrel cage induction motor, refrigerant suction gas cooled and hermetically sealed.

Oil separator, oil cooler and filtration devices are provided separate from the compressor. Check valves in the compressor discharge and lube oil system and a solenoid valve in the lube system are provided.

Evaporator

Shell and tube evaporator. Carbon steel shell plates and tube sheets. Tubes sheets are drilled reamed and grooved to accommodate tubes. Individually replacable tubes, mechanically expanded into tube sheets and fastened into intermediate tube supports made of plastic Headers of high strength cast steel bolted to the tube sheets. Self energizing type gaskets requiring low bolt torque.

Direct expansion type evaporator. Factory insulated with 19 mm Armaflex type foam. internally finned 5/8 inch diameter tubes. Maximum operating pressure: water side and refrigerant side = 1.4 MPa.

Refrigerant circuit

Each circuit includes: electronic expansion valve minimizing evaporator superheat, removable core filter drier.

Control panel

All unit controls are housed in a watertight enclosure. Removable plate on the top of the enclosure to allow customer connection of power wiring and remote interlocks.

Microcomputer control provides all control functions including start-up and shut down, leaving chilled water temperature control, compressor and expansion valve modulation, antire-cycle logic and load limiting.

«Adaptive Control™» microprocessor prevents unit shutdown due to abnormal operating conditions associated with low refrigerant temperature, high condensing temperature and motor overload.

Unit protective functions include loss of chilled water flow, evaporator freeze protection, low or high refrigerant pressure, reverse rotation, compressor starting and running over current, phase loss, phase imbalance, phase reversal and loss of oil flow.

The Clear Language Display (CLD) eliminates coded informations. Information available with the «Adaptive Control™» microprocessor includes : entering and leaving evaporator water temperatures, refrigerant temperatures and pressures, compressor suction temperature,

compressor start and running hours, chilled water setpoint, over 90 diagnostic and operating conditions.

Starter panel

Part winding starters. Typically TRANE helirotor screw compressor are up to full speed in less than one second.

Rigging

4 liftings lugs are provided on the unit base frame.

Option and accessories

- Ice making module,
- Communication interface/Remote control display board,
- Ammeter-voltmeter,
- Compressor sound enclosure,
- Disconnect switch,
- Pressure gauges.

Factory run tests

Pressure test on each individual component (before assembly) and on the refrigeration circuit (when fully assembled).

Shipment

All units ship on a wooden skid with separated oil charge and nitrogen holding charge.

Quality assurance

The Quality Management System applied by TRANE has been subject to independent third party assessment and approval to ISO 9001. The products described in this catalogue are designed, manufactured and tested in accordance with the approved system requirements as described in the Trane Quality Manual.

RTCA Mechanical specifications

TRANE series RTCA air cooled refrigerant condensers for outdoor installation, consisting of:

Frame

Bolted frame assembly of steel profiles.

Profiles and panels of galvanized steel have a corrosion resistant finish of polyurethane paint.

Condenser coils

Coils in a V shaped arrangement. Integral subcooler.

Aluminium fins mechanically bladed to internally finned seamless copper tubing.

Condensing coils are leak tested at 35 Mpa prior to assembly, dehydrated and hermetically sealed with a nitrogen holding charge.

Outdoor air temperature sensor and saturated condensing refrigerant temperature sensor for each circuit are factory installed.

Fans

Axial fans, each with 6 blades of aerofoil section, moulded from black, ultra violet stabilized, glass fiber reinforced polypropylene, with an aluminium hub and clamp-plate. All rotating aluminium components are X-ray tested prior to machining. Balanced according to BS6861 PART 1 1987 (ISO 1940 - 1986).

Motors

Three phase, fully enclosed fan motors, permanently lubricated, protection class IP 55. Nominal motor speed 915 rpm (Standard version), 680 rpm (Low Noise version).

All motors can be reconnected to an approx. 20% lower speed.

Starter panel

The unit mounted starter panel shall be to class IP 55 protection. The panel shall contain fan motor starters, overloads and disconnect switch.

Options

- Copper fin condenser coil,
- Started panel, two speed, unit mouted, including starters, overloads and disconnect switch. Suitable for low ambient head pressure control and fan night noise set back.

Quality assurance

Product designed, manufactured and tested under TRANE quality assurance system approved to ISO 9001.



Société Trane
Route de Chamagne
F - 88130 Charmes
France

<http://www.trane.com>

An American Standard Company



K15 CA 014 E - 0999

Supersedes K15 CA 014 - 1098

Literature stocking location : Europe

Trane reserves the right to alter any information without prior notice.

Société Trane - Société Anonyme au capital de 41 500 000 F - Siège Social : 1, rue des Amériques - 88190 Golbey - France - Siret 306 050 188-00011 - RCS Epinal B 306 050 188 Numéro d'identification taxe intracommunautaire : FR 83 306050188

